



Style Guide

PHOTOGRAPHY

UPDATED 08/2013

Overview	2
Product Angles	3-10
Product Placement	11-13
Product Scaling	14-25
Metal Color Guide	26
Lighting and Reflections	27-29

USING THE EXCHANGE BACKGROUNDS IN PHOTO SHOOTS

The primary Exchange backgrounds are ONE flattened layer that includes both a grey/white gradient and the Exchange generic white.

The complete (background and product) file must meet these requirements:

- 1000 pixels x 1000 pixels
- 300 dpi
- provided in .PSD and .JPG formats

WEB PURPOSES

Product Imagery for the Web must meet these requirements:

- 1000 pixels x 1000 pixels
- 72 dpi
- optimized at Medium, 70K maximum

THE FINE DETAILS

PERSPECTIVE

All product categories (except for necklaces/pendants) must be shot at a top angle. See examples.

LIGHTING

All product categories must be shot in the same white lighting. Each metal (i.e. rose gold, platinum) must look like a seamless family. All imperfections (dark spots, saturated colors) must be removed. See examples.

SHADOWS

Every product category (except for necklaces/pendants) must be accompanied with a shadow. It should sit kiss the product at the bottom and be at an opacity that creates a natural effect.

REFLECTIONS

For unnatural reflections, use the motion blur tool (Photoshop) at 12% opacity (or stronger where applicable).

RE-TOUCHING

All extraneous markings (i.e. "Alloy" on rings) should be removed (in Photoshop) and cloned to create a natural blend.

VERTICAL ALIGNMENT

The product should be vertically aligned with the background.

HORIZONTAL ALIGNMENT

Product baseline should align to level specified below.

NAMING FILES

- Main Image: UPC_ItemKey.jpg
- Alternate Image 1: UPC_itemKey_2.jpg
- Alternate Image 2: UPC_ItemKey_3.jpg





DIAMOND BRACELETS

Baseline must align to C level

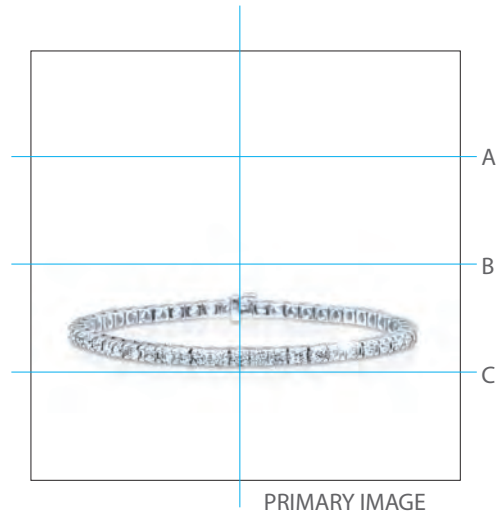

DIAMOND STUDS

Baseline must align to C level

PRIMARY IMAGE

Shot as a pair
 Left Earring shot straight on
 Right Earring shot slightly angled with backing showing

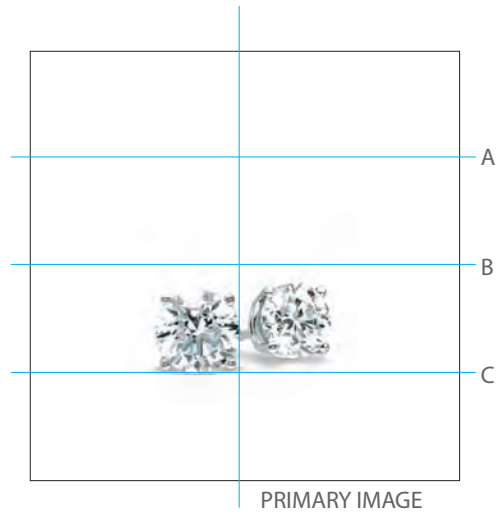

ALTERNATE IMAGE 1

Shot as a pair
 Shot straight on

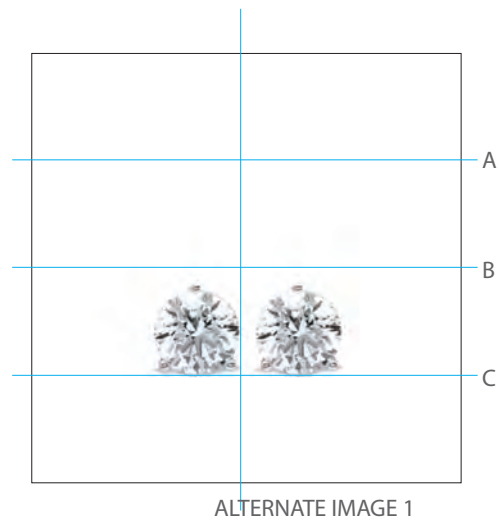

ALTERNATE IMAGE 2

Shot as a pair
 Left Earring shot straight on
 Right Earring shot side view

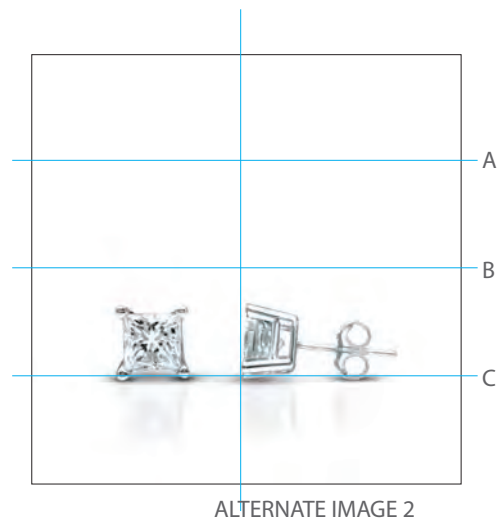

DIAMOND HOOPS

Baseline must align to C level

PRIMARY IMAGE

Shot as a pair

Left Earring shot angled/open

Right Earring shot slightly angled with back showing

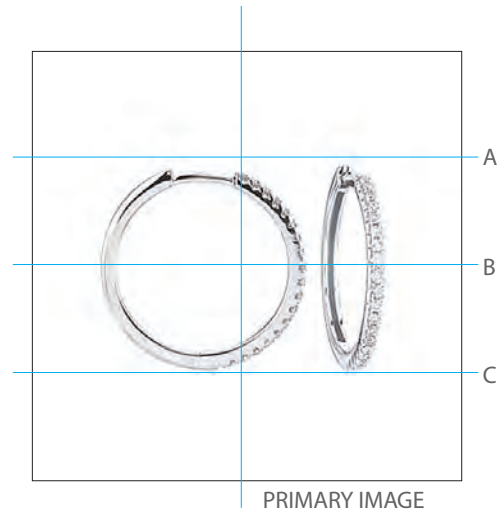

ALTERNATE IMAGE 1

Shot as a pair

Shot angled right

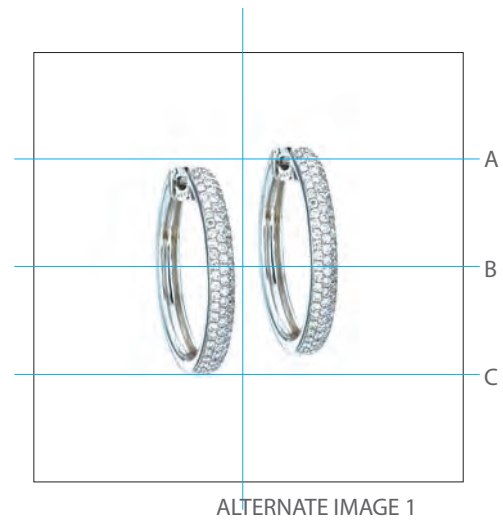

DIAMONDS BY THE YARD, NECKLACES

Baseline must align to C level

PRIMARY IMAGE

Detail shot
Three stones showing
Fading at top



ALTERNATE IMAGE 1

Shot straight down
Show whole necklace, clasped

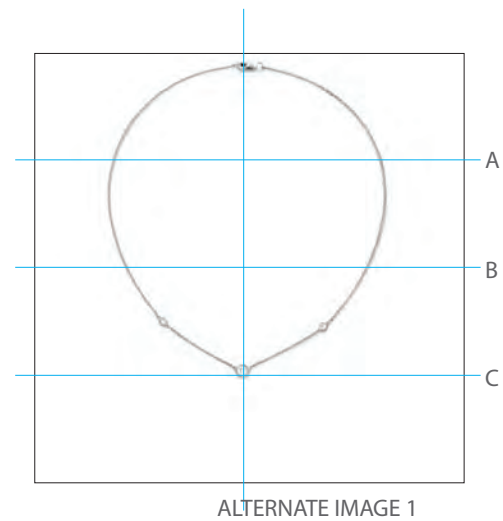

DIAMONDS BY THE YARD, BRACELETS

Baseline must align to C level

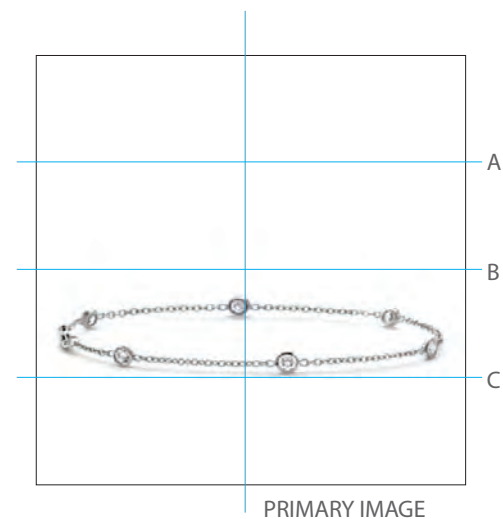

GOLD, CHAINS

Baseline must align to C level

PRIMARY IMAGE

Detail shot
Stations showing
Fading at top

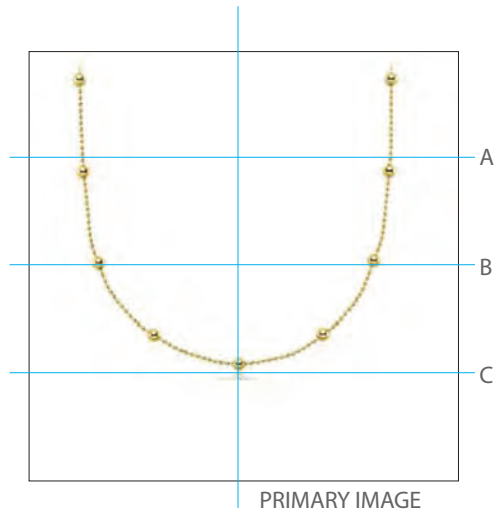

ALTERNATE IMAGE 1

Shot straight down
Show whole necklace, clasped

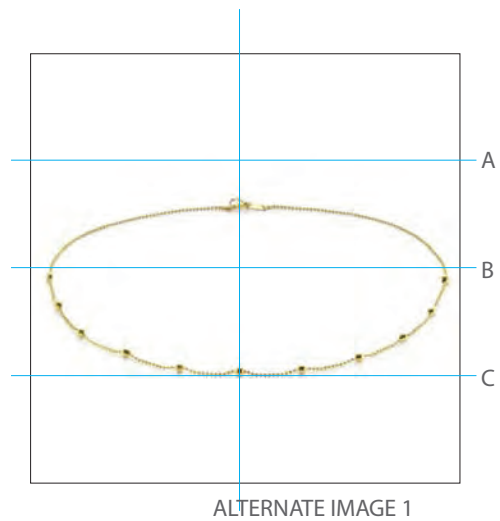

GOLD, BRACELETS

Baseline must align to C level



PEARL, STRANDS

Baseline must align to C level

PRIMARY IMAGE

Detail shot
Fading at top



ALTERNATE IMAGE 1

Shot straight down
Show whole necklace, clasped



PEARL, BRACELETS

Baseline must align to C level



PENDANTS

Baseline must align to C level

PRIMARY IMAGE

Shot straight on, in detail
Only show 1 inch of chain
Faded at top



RINGS

Baseline must align to C level

PRIMARY IMAGE

Shot slightly angled with back showing
1/4 inch of space exposed in middle of ring



ALTERNATE IMAGE 1

Shot at angled left, aligned to diagonal axis



ALTERNATE IMAGE 2

Align horizontally and vertically
Shot straight down
Birdseye view

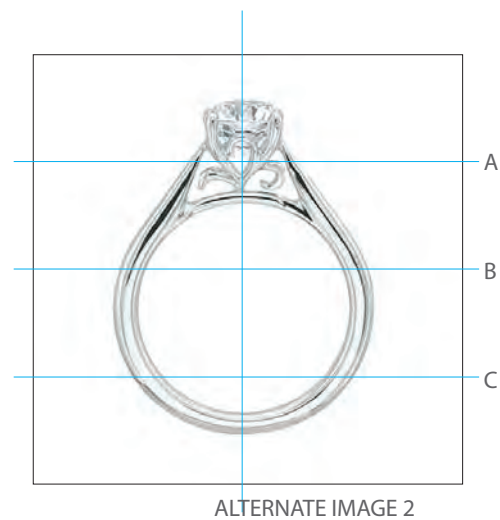

NECKLACES

Baseline must align to C level
 Shot in detail (not whole)
 Open to 1½ inches at the widest part (top)
 Faded at top

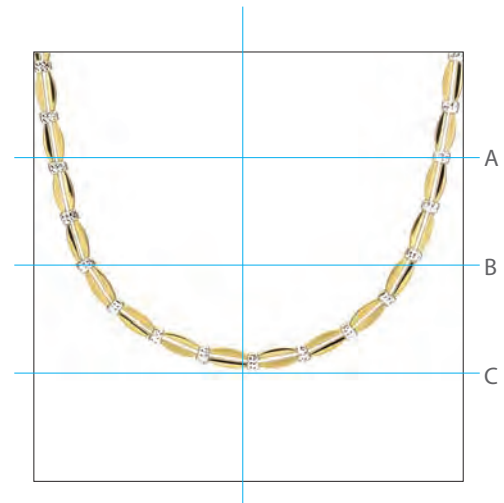
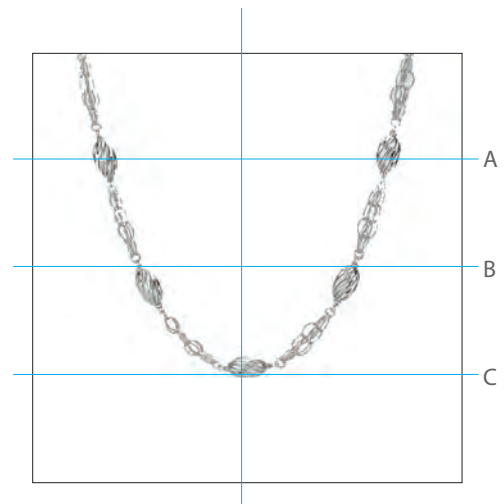
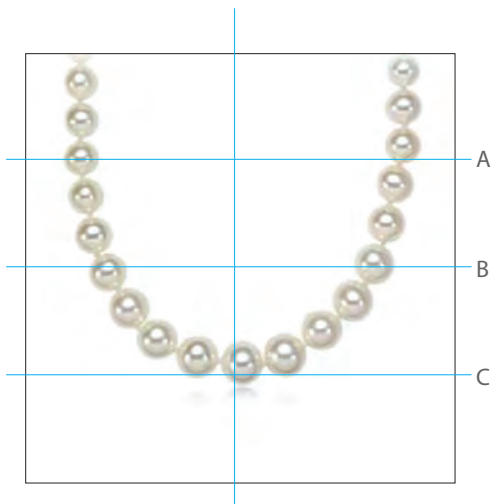
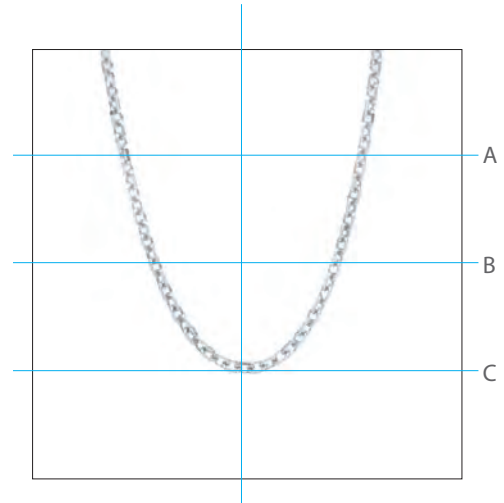
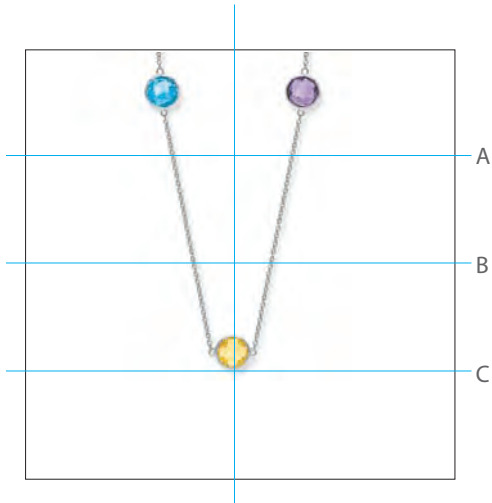

PENDANTS

Baseline must align to C level
 Shot in detail (not whole)
 Open to 1/2 inches at the widest part (top)
 Faded at top

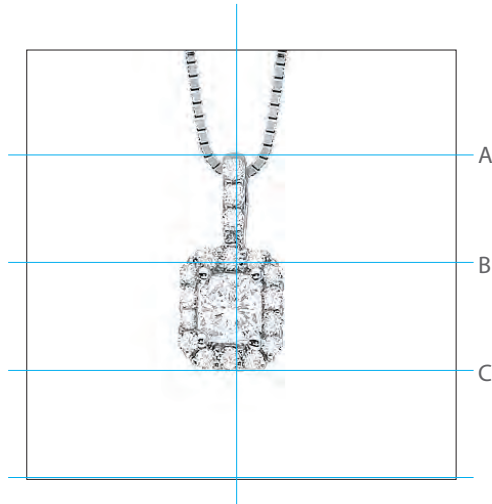

SOLITAIRE PENDANTS

Baseline must align to C level
 Shot in detail (not whole)
 Open to 1/2 inches at the widest part (top)
 Faded at top

CHAIN AND BALE

Chain/bale must be taken from the smallest size pendant and applied to all size stones.
 Deselect the chain/bale before enlarging stones.

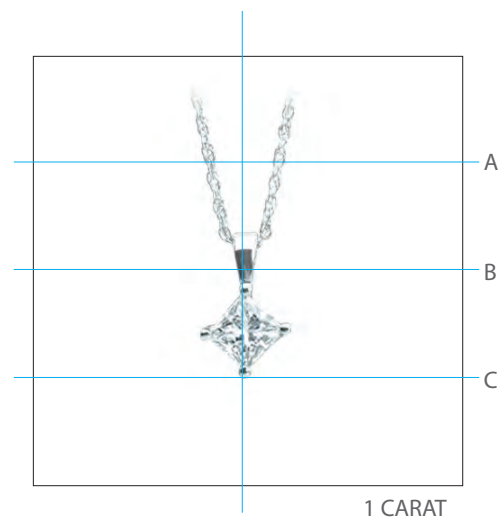
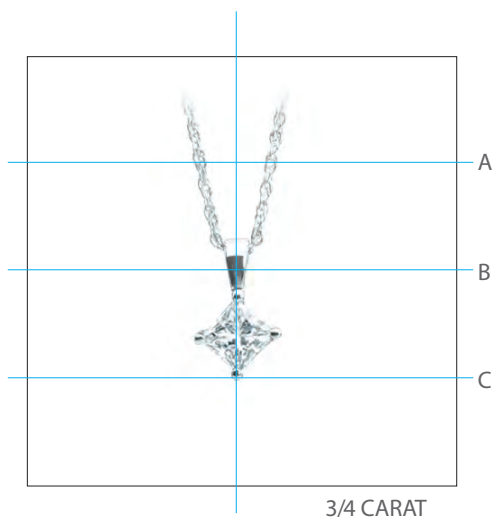
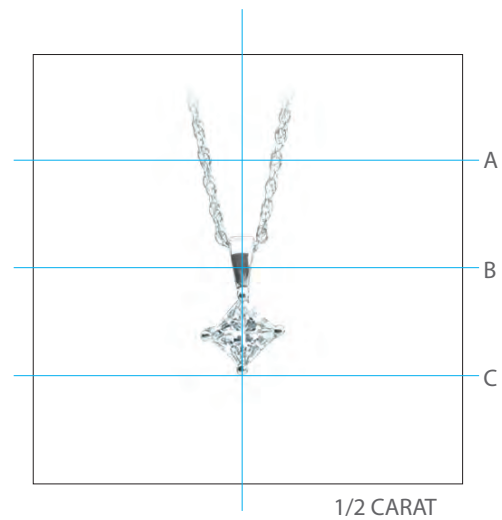
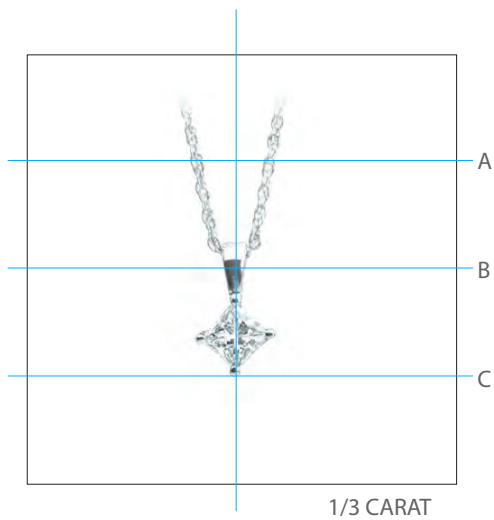

COMPOSITE AND HALO PENDANTS

- Baseline must align to C level
- Shot in detail (not whole)
- Open to 1/2 inches at the widest part (top)
- Faded at top

CHAIN AND BALE

- Chain/bale must be taken from the smallest size pendant and applied to all size stones.
- Deselect the chain/bale before enlarging stones.



HEART PENDANTS

- Baseline must align to C level
- Shot in detail (not whole)
- Open to 1/2 inches at the widest part (top)
- Faded at top

CHAIN AND BAILE

- Chain/bale must be taken from the smallest size pendant and applied to all size stones.
- Deselect the chain/bale before enlarging stones.

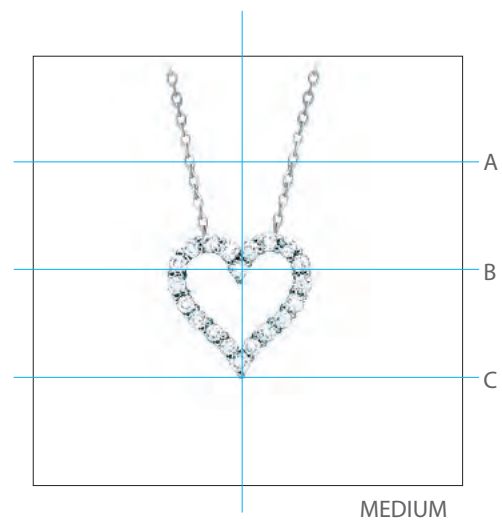

EARRINGS

See various shapes
Baseline must align to C level

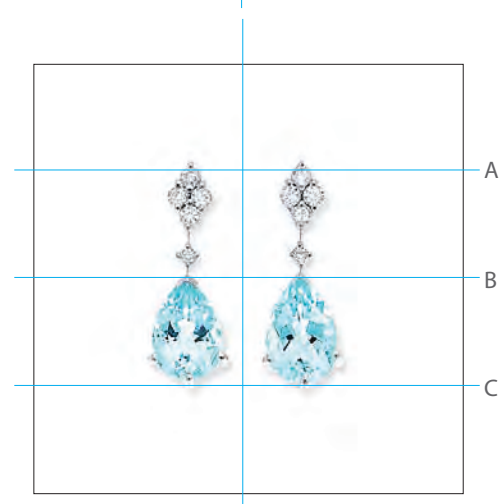
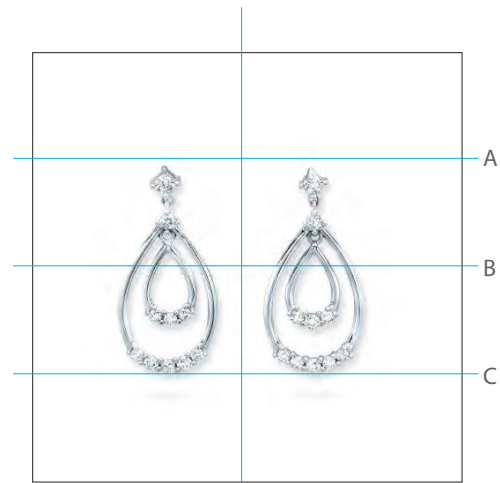
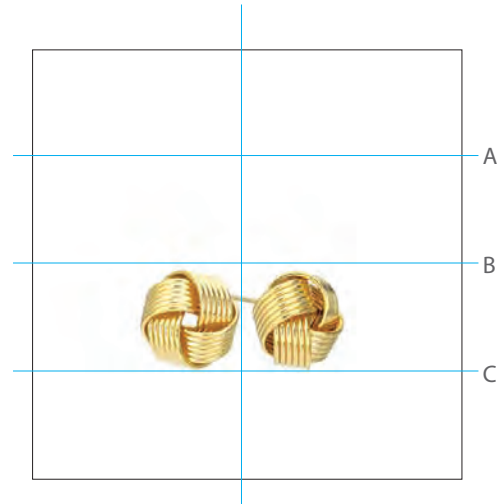

DIAMOND SOLITAIRE EARRINGS

Baseline must align to C level

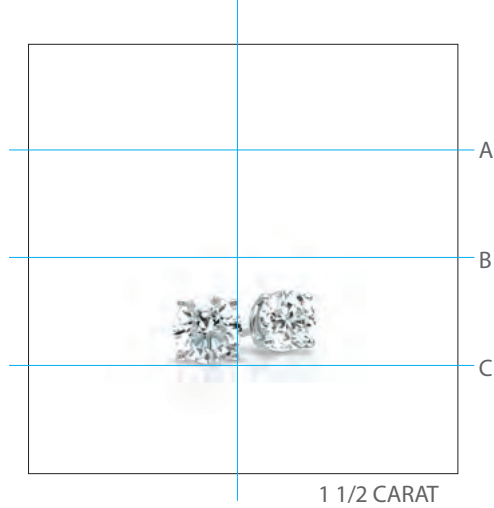
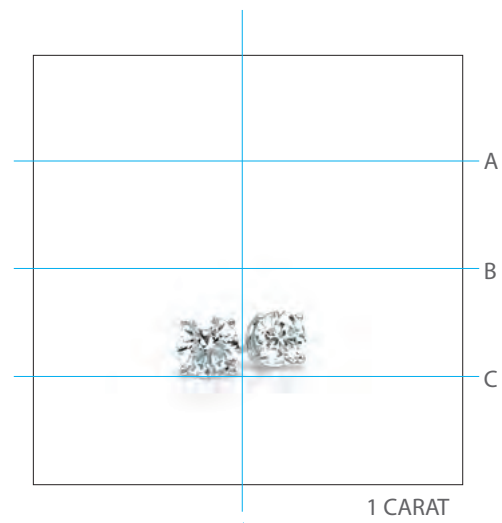
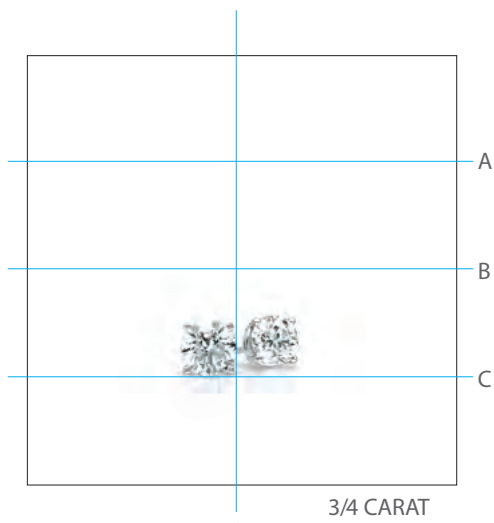
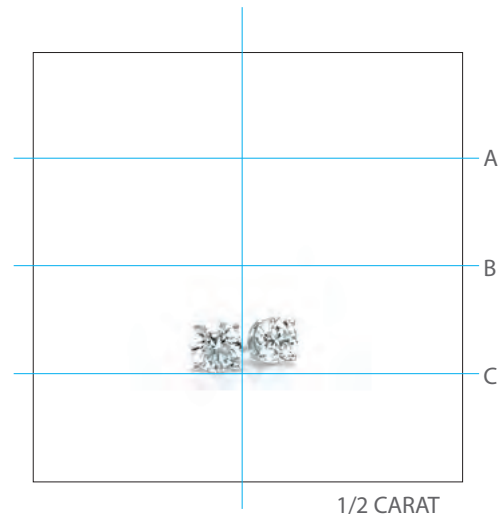
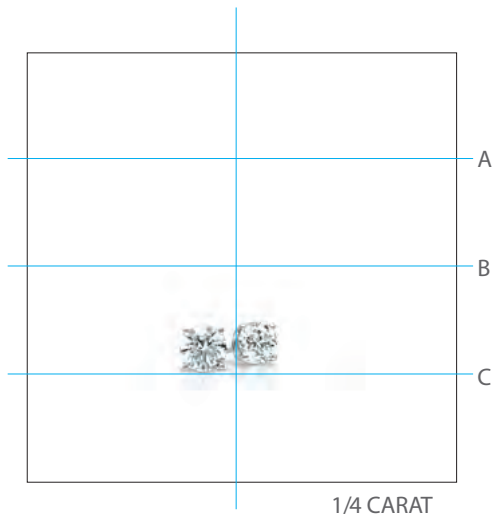

PEARL STUD EARRINGS

Baseline must align to C level

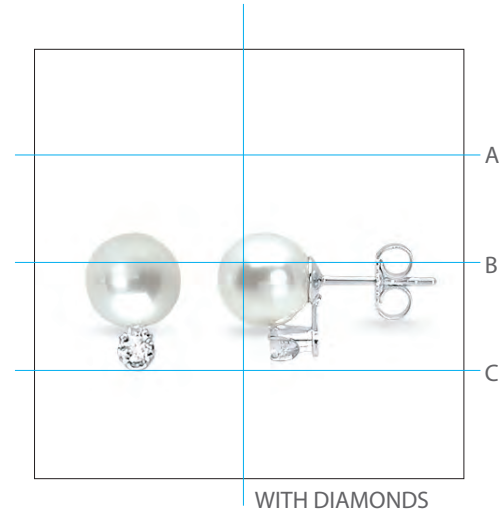
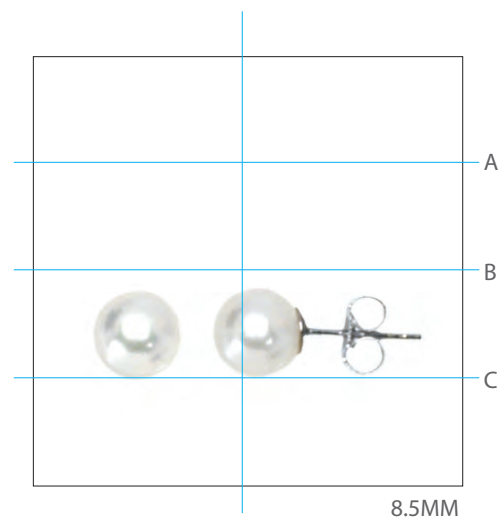
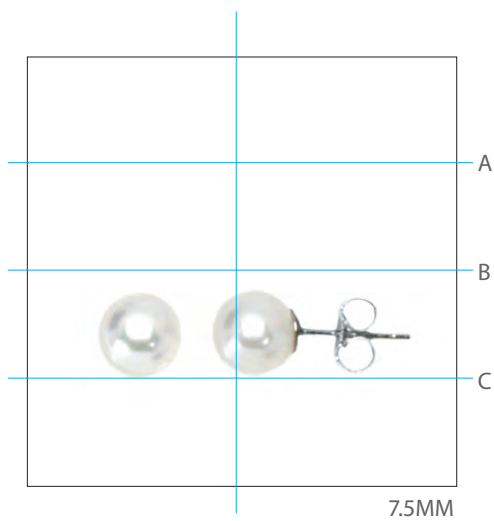
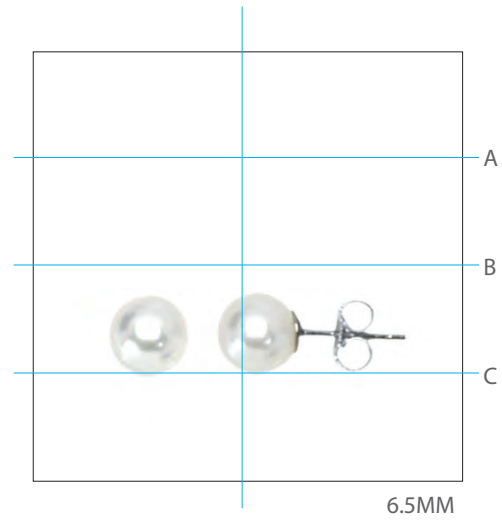
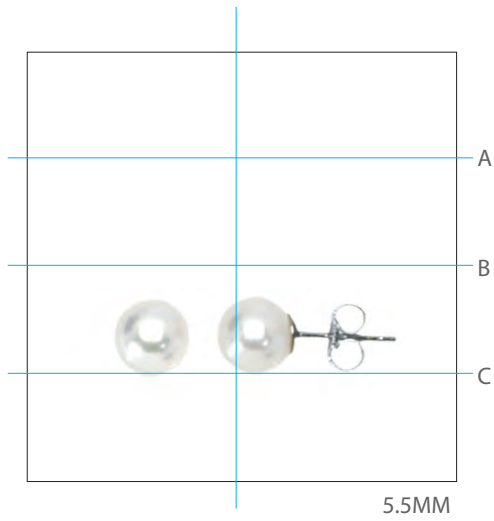

COMPOSITE AND HALO EARRINGS

Baseline must align to C level

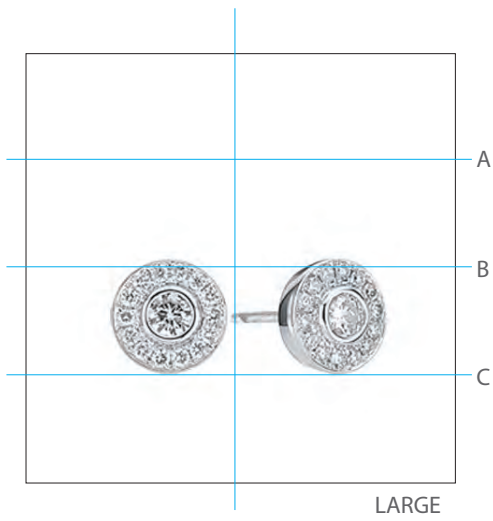
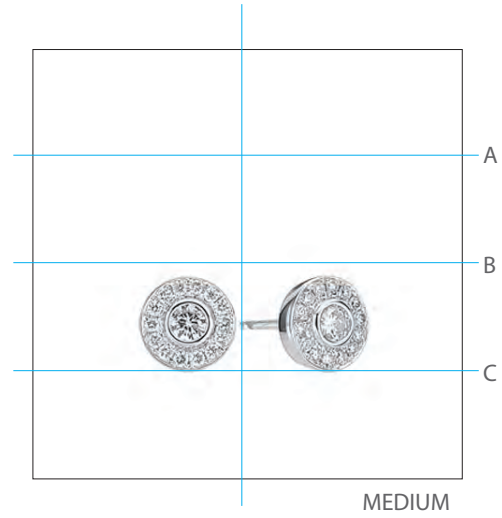
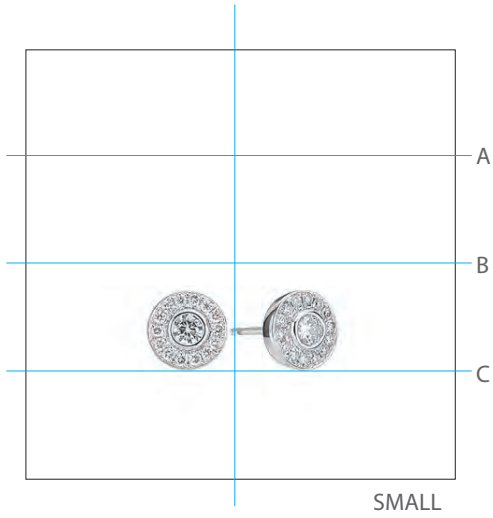

DIAMOND HOOP EARRINGS

Baseline must align to C level

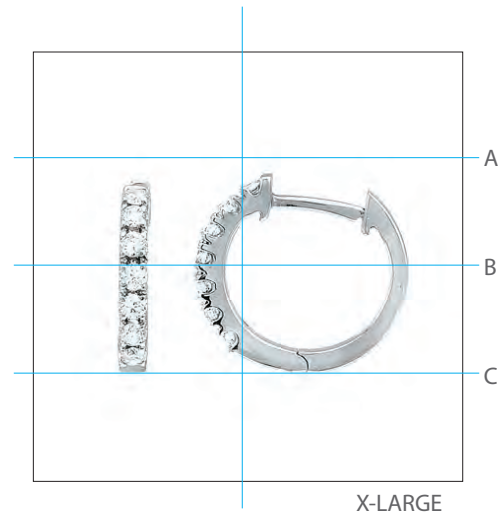
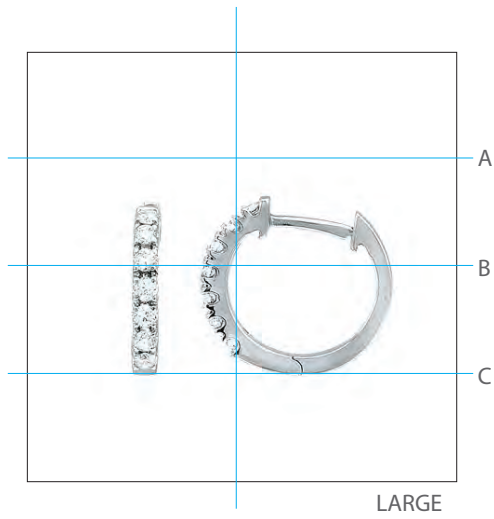
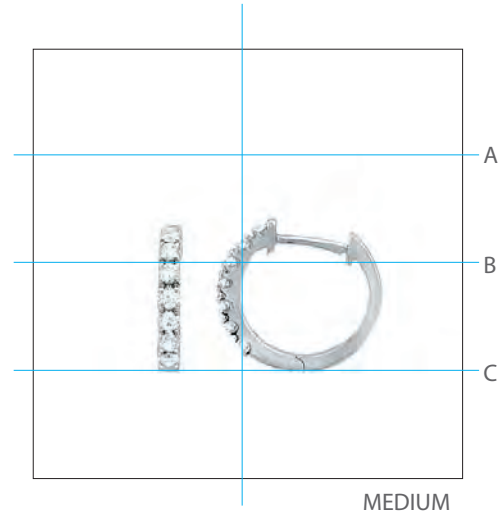

GOLD HOOP EARRINGS

Baseline must align to C level

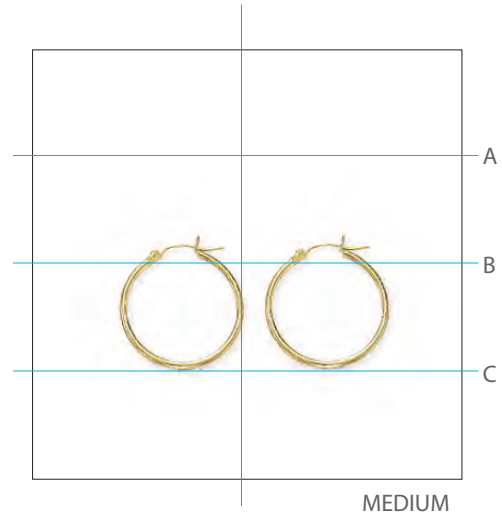

BRACELETS

Baseline must align to C level

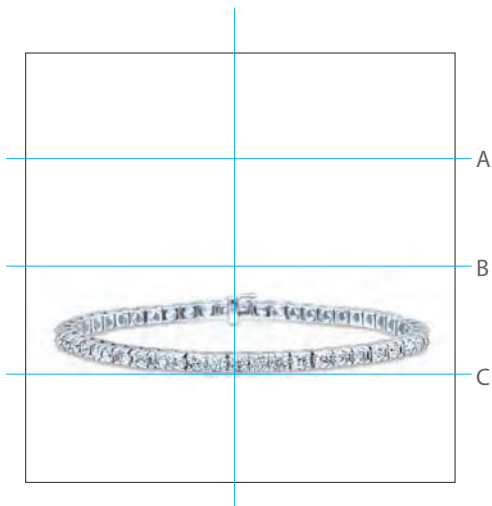

JEWELRY SETS

3-Piece Pearl Set includes: Bracelet, Strand and Studs
Earrings align to C level

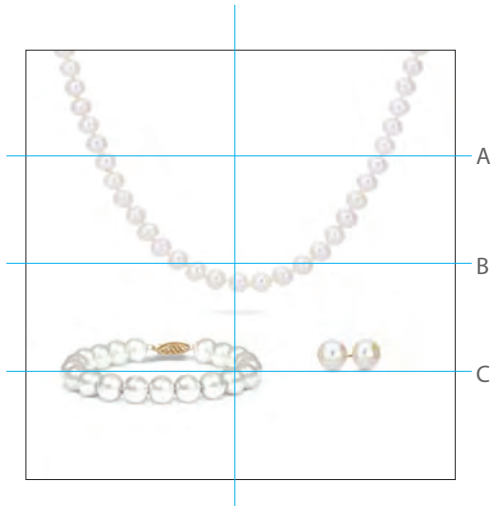

RINGS

Non-Engagement
Baseline aligns to C level
.3125" margin on either side

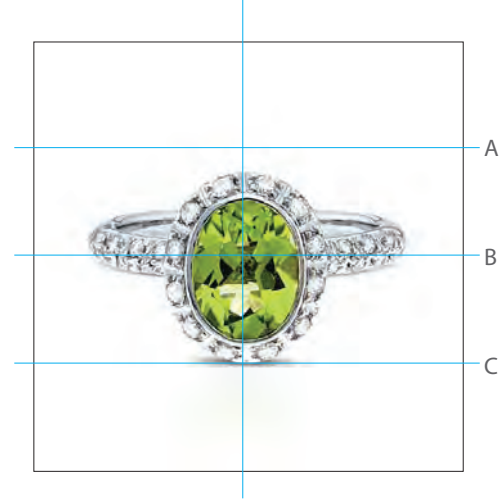

ENGAGEMENT RINGS

Band must be taken from the smallest size Solitaire Ring and applied to all re-sized prongs and stones



1/3 CARAT



1/2 CARAT



3/4 CARAT



1 CARAT



1 1/2 CARAT



2 CARAT

ENGAGEMENT RINGS

METAL COLOR GUIDE



WHITE GOLD



YELLOW GOLD



PLATINUM

LIGHTING AND REFLECTIONS

All rings should not show black spots or dark areas in the diamond, shank or band. Metal color should be true to standard. Refer to PAGE 26.



BLACK REFLECTED IN SHANK



BLACK REFLECTED IN SHANK

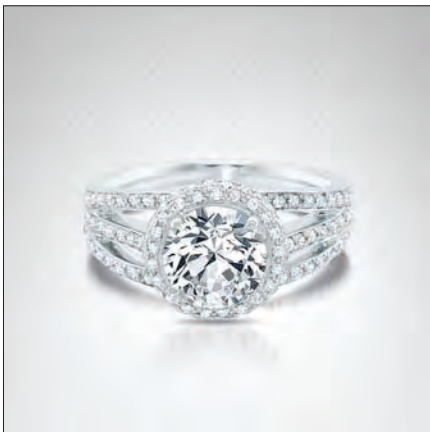

CORRECT COLORING - WHITE GOLD

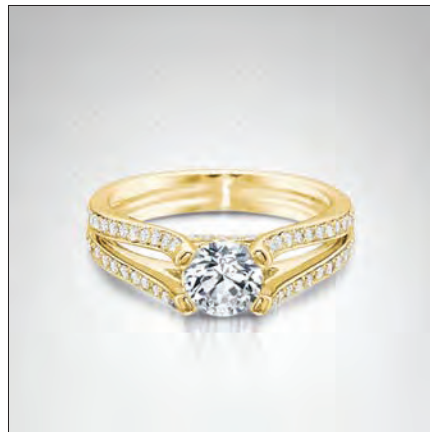

CORRECT COLORING - YELLOW GOLD



CORRECT COLORING - PLATINUM

LIGHTING AND REFLECTIONS

All rings should not show black spots or dark areas in the diamond, shank or band



BLACK SPOTS IN METAL



BLACK SPOTS IN METAL



BLACK SPOTS IN METAL

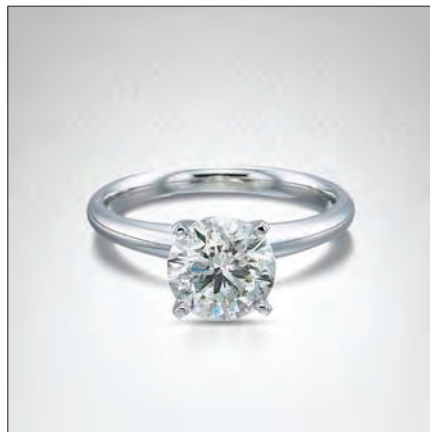

CLEAN METAL

LIGHTING AND REFLECTIONS

All rings should not show black spots or dark areas where other parts of the ring or set can cast shadows



POOR LIGHTING

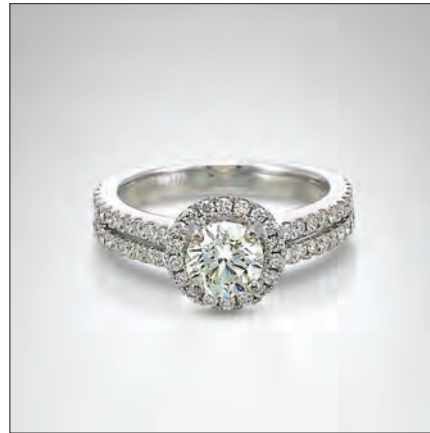

POOR LIGHTING



CORRECT LIGHTING



CORRECT LIGHTING

LIGHTING AND REFLECTIONS

All stones should show as many facets as possible and be void of dark shadows and pockets.



DARK SHADOWS



DARK SHADOWS



CLEAR STONE



CLEAR STONE